

MONO

Motive motors are built according to international standard regulations; each size throughout the construction forms is calculated with reference to the tables of standard IEC 72-1.

The frame is made in die casting aluminium alloy.

All MONO motors are single phase 230V 50Hz. On request 60Hz and special voltages
F class insulation, (H on request)
S1 continuous duty service,
IP55 protection (IP56, 66 and 67 on request)
on request extra capacitor for high starting torque



The special winding permits a good starting torque even without a double capacitor start/run



Bearings selected for their silence and reliability and, for the same objectives, the rotor is dynamically balanced.



Aiming the maximum protection, the motors are equipped with important details like the pull-resistant cable gland and the combination of bearings with two shields each with rubber seal rings



The connection box can be rotated



Feet are detachable, and can be fixed on 3 sides of the housing, thus permitting the terminal box to be positioned up, right or left.

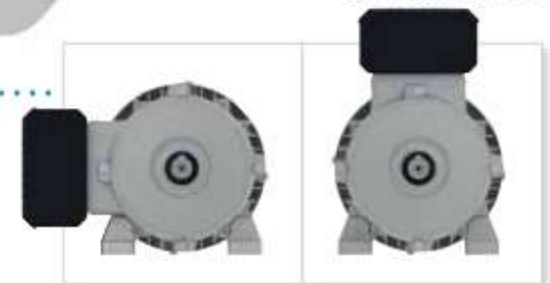

PERFORMANCE TABLE

Type	KW	rpm	I _n (A)	I _s (A)	I _s ----- I _n	C _n (Nm)	C _s (Nm)	C _s ----- C _n	η % 100%	Pwr. Fact. cos φ	ΔT run (°C)	ΔT starting (°C)	capacitor run (μf)	With extra start capacitor		
														I _s ----- I _n	C _s ----- C _n	capacitor start (μf)
63A-2	0,18	2824	1,42	4,16	2,9	0,61	0,67	1,1	56,43	0,978	52	69	12	4,0	2,7	10
63B-2	0,25	2844	2,20	6,57	3,0	0,84	0,92	1,1	56,71	0,870	83	77	14	3,7	2,1	10
71A-2	0,37	2789	2,63	7,98	3,0	1,27	1,14	0,9	66,24	0,924	58	65	14	4,2	2,7	30
71B-2	0,55	2797	4,24	11,75	2,8	1,88	1,69	0,9	64,48	0,874	93	103	20	4,2	2,3	30
80A-2	0,75	2809	4,90	16,99	3,5	2,55	2,04	0,8	71,51	0,931	81	92	22	4,1	2,2	50
80B-2	1,1	2853	7,72	20,24	2,6	3,68	2,58	0,7	74,66	0,830	87	92	25	2,7	1,7	50
90S-2	1,5	2878	9,45	41,17	4,4	4,92	2,96	0,6	74,66	0,917	76	86	45	4,5	1,7	80
90L-2	2,2	2845	13,42	59,83	4,5	7,39	17,67	2,4	78,20	0,910	95	98	40+150			
63B-4	0,18	1394	1,75	4,19	2,4	1,23	1,23	1,0	51,07	0,876	91	97	8	2,8	1,9	10
71A-4	0,25	1413	1,88	6,03	3,2	1,69	1,52	0,9	61,24	0,944	63	79	12	4,5	2,6	20
71B-4	0,37	1423	3,01	9,75	3,2	2,48	2,79	1,1	56,31	0,948	78	101	15	4,3	2,4	30
80A-4	0,55	1437	4,07	12,30	3,0	3,66	2,56	0,7	67,07	0,875	86	98	16	4,3	2,4	50
80B-4	0,75	1382	5,32	14,36	2,7	5,18	3,11	0,6	66,61	0,920	100	101	20	3,7	1,9	50
90S-4	1,1	1402	7,28	20,32	2,8	7,49	5,25	0,7	71,23	0,922	71	92	35	2,8	1,7	50
90L-4	1,5	1414	9,74	20,50	2,1	10,13	7,09	0,7	75,12	0,891	80	80	45	2,1	1,3	50
100LA-4	2,2	1460	13,19	63,25	4,8	14,39	16,61	1,2	84,50	0,858	93	82	40+120			
100LB-4	3	1442	17,15	20,58	1,2	19,87	19,87	1,0	81,78	0,930	80	101	80+120			
112M-4	4	1451	23,03	20,73	0,9	26,33	18,43	0,7	84,28	0,896	89	95	80+150			



DIMENSIONS



TYPE	POLES	AC	AD	H	KK	L	D	DH	E	Q	F	G	B3						B5						B14						L
													A	AB	B	C	HA	K	M	N	P	R	S	T	M	N	P	R	S	T	
63	2-8	121	116	63	PG11	209	11	M4	23	3	4	8,5	100	120	80	40	10	7	115	95	140	0	10	3	75	60	90	0	M5	2,5	275
71	2-8	137	126	71	PG11	242	14	M5	30	3	5	11,0	112	136	90	45	11	7	130	110	160	0	10	3,5	85	70	105	0	M6	2,5	310
80	2-8	155	146	80	PG16	276	19	M6	40	3	6	15,5	125	155	100	50	13	10	165	130	200	0	12	3,5	100	80	120	0	M6	3,0	350
90S	2-8	176	149	90	PG16	299	24	M8	50	5	8	20,0	140	175	100	56	15	10	165	130	200	0	12	3,5	115	95	140	0	M8	3,0	380
90L	2-8	176	149	90	PG16	324	24	M8	50	5	8	20,0	140	175	125	56	15	10	165	130	200	0	12	3,5	115	95	140	0	M8	3,0	405
100	2-8	194	160	100	PG16	366	28	M10	60	5	8	24,0	160	192	140	63	16	12	215	180	250	0	14	4	130	110	160	0	M8	3,5	465
112M	2-8	219	170	112	PG16	379	28	M10	60	5	8	24,0	190	224	140	70	16	12	215	180	250	0	14	4	130	110	160	0	M8	3,5	480

ATDCM AT24M
L
275
310
350
380
405
465
480

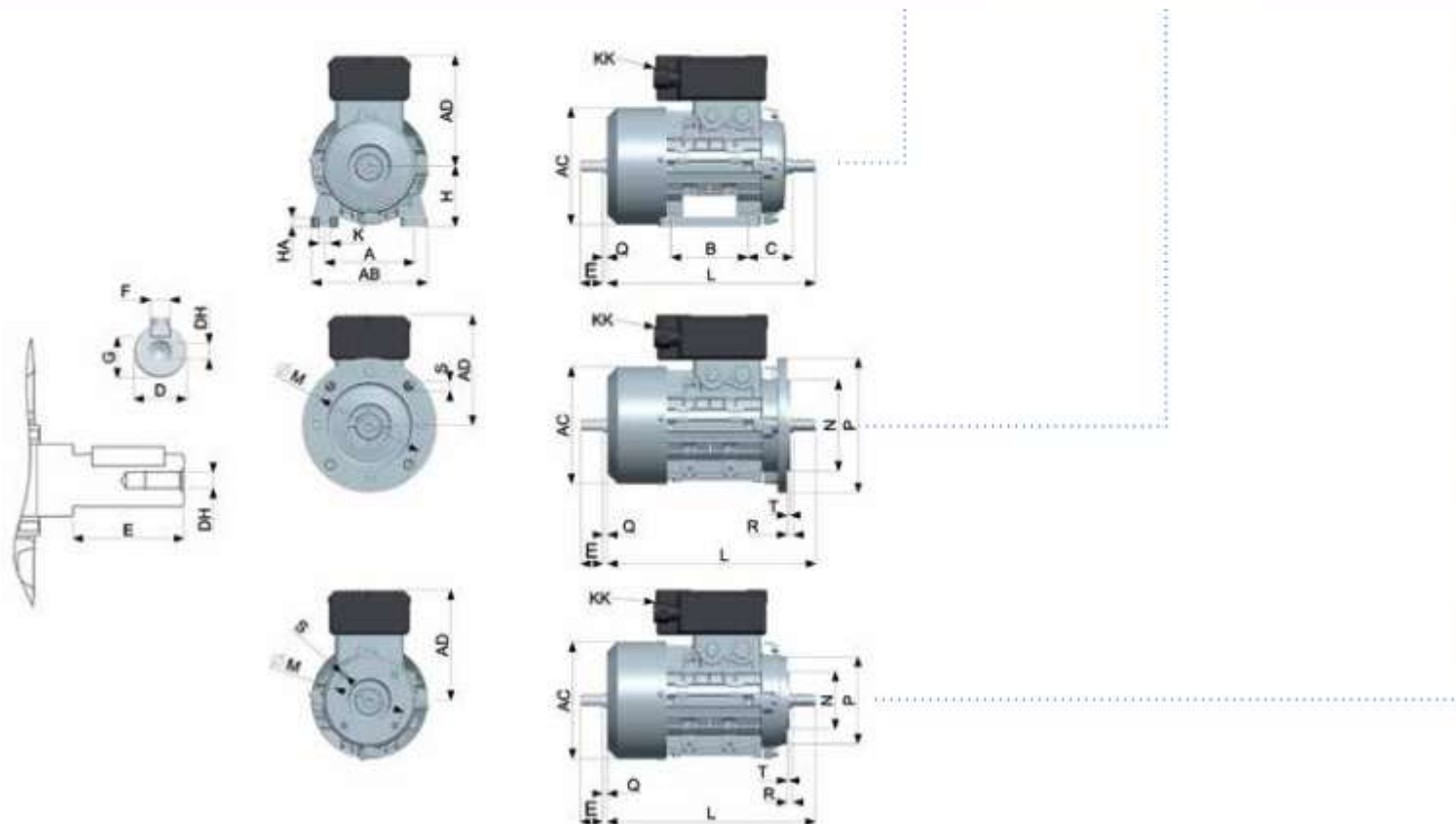

you can download 2D and 3D drawings from www.motive.it

1PH SELF-BRAKING MOTORS SERIES MONO ATM

MONO ATDCM and AT24M series selfbraking motors use one or 2 spring-pressure brakes, firmly spliced onto a cast iron shield at the back of the motor.

These motors include a series of characteristics normally considered options by other brands, like:

- The standard hand lever permits to release the brake, making it possible to move manually the shaft
- The PTO thermal protectors in the winding are a standard

On ATDCM, the separate brake power supply is achieved, whenever needed, by connecting directly to the brake terminal board located inside the motor terminal box.

IEC Type	ATDCM						AT24M				ATDCM AT24M
	Static max braking torque [Nm]	standard vers. braking time no-load [Sec]	"TA version" braking time [Sec]	input voltage on rectifier [Vac]	output voltage to brake [Vdc]	brake power [W]	Static max braking torque [Nm]	Static min braking torque [Nm]	Braking time no-load [Sec]	brake power [W]	extra Kg on std
AT.M63	4,5	0,15	<0,05	220-280	99-126	20	4,5	4,0	0,06	20	+4
AT.M71	8,0	0,15	<0,05	220-280	99-126	28	4,5	4,0	0,06	20	+5
AT.M80	12,5	0,20	<0,05	220-280	99-126	30	10,0	9,0	0,09	25	+5,5
AT.M90	20,0	0,25	<0,05	220-280	99-126	45	16,0	12,0	0,11	45	+6
AT.M100	38,0	0,30	<0,05	220-280	99-126	60	32,0	28,0	0,14	60	+7
AT.M112	55,0	0,35	<0,05	220-280	99-126	65	60,0	55,0	0,15	65	+10

On request, the brakes can be modified to be extremely silent for usage in special environments like theatres.

ATDCM

BRAKE DESCRIPTION

The MONO AT... series brakes are electromagnetic brakes with negative operation, whose braking action is exercised in the absence of power supply.

The brakes insulation class is F.

The brakes lining is asbestos-free.

The rectifier is of relays type, with protection varistors at the entry and the exit. All brake assemblies are protected against corrosion by painting or heat galvanizing and resined winding. The parts most subject to wear are treated in special atmospheres that provide considerable wear resistance to the parts.

BRAKE OPERATION

When the power supply is interrupted, the excitation coil ⑦ is no longer powered and therefore doesn't exert the magnetic force necessary to restrain the mobile armature ①, which, pushed by the pressure springs ②, compresses the brake disk ③ against the motor flange ④ on one side and the armature itself on the other, thereby creating a braking action.

AT24M

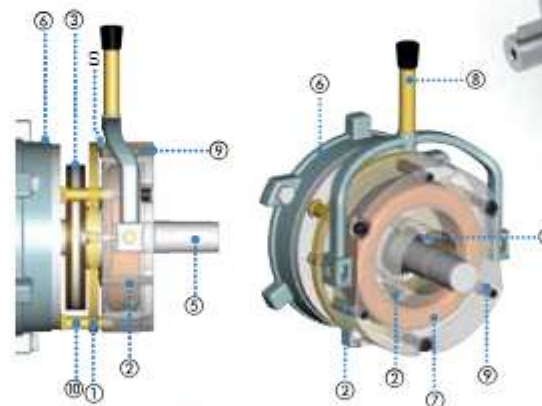

- ① Mobile armature
- ② springs
- ③ Brake disc
- ④ Driver
- ⑤ Motor shaft
- ⑥ Motor flange
- ⑦ Electromagnet
- ⑧ Release lever
- ⑨ Adjuster screws
- ⑩ Threaded bush
- ⑪ braking torque setting knob
- S Air gap

ADJUSTMENT

Two different types of adjustment are possible (download the technical manual from www.motive.it)

Between electromagnet ⑦ and the mobile armature.

The braking torque is set to its max level by Motive, but it can be decreased by acting on the adjuster screws ⑨ (ATDCM motors) or on the knob ⑪ (AT24M).

MANUAL RELEASE

Motive brake motors are supplied with the manual release lever in their standard version. If not wished, the lever is like a screw, that can be taken away simply turning it.



In order to safeguard the braking torque, it is necessary to clean periodically the parts inside the rubber ring seal by the dust created by the disc lining.



IP

ATC brakes are IP66 under an electrical point of view, but mechanically, in case of an outdoor use, they should be protected by rust and by disc adhesion effects given by humidity. In such a case, we suggest to use our protective rubber ring seals. This device prevents the exit or ingress of dust, humidity, dirt, etc., out of or into the braking area. It is inserted into the groove on the stator. If your brake doesn't have such a groove, you must order a specifically machined brake for that.

STAINLESS STEEL BRAKING SURFACE

When high humidity in the air can rust fastly the contact surface between the brake disc and the cast-iron NDE shield of the motor, you can request to motive to add a stainless steel shield.



MICRO-SWITCHES TO DETECT BRAKE POSITION

Optional.

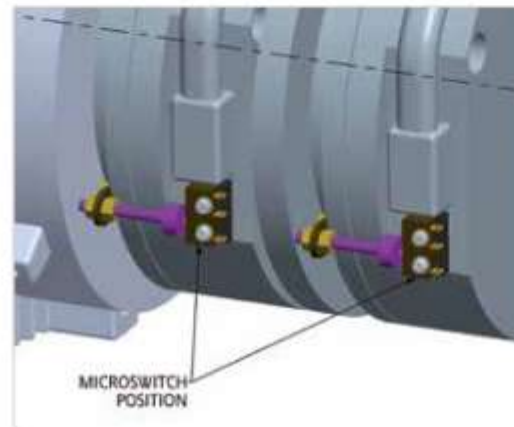

POWER SUPPLY

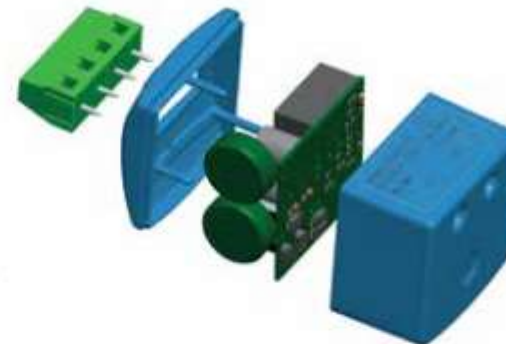

ATDCM brakes are DC brakes power supplied by a rectified installed inside the motor main terminal box.

Unless there's a different request of the client, motive supplies ATDCM brake

motors with the rectifier already connected directly to the main terminal block of the motor, in order to permit to the motor switching to act at the same time on the brake.

In case that the motor is used to move loads which can have an inertial movement, like lifted weights (such inertial movement can move the motor when the power is switched off, and the motor can act like a generator on the rectifier avoiding the brake locking), disconnect the motor main terminal board from the rectifier, and connect separately the rectifier (ATDC)

TA special rectifier permits to solve the problem of inertial movements with no need for a separate power supply to the rectifier.

This exclusive rectifier offers the following innovations:

- double semi-wave technology.
- special vibration proof 6 Ampere relays (like the ones used on Ducati race motorbikes).
- electric arcs ultra resistant contacts in silver alloy.
- relays system instead of normal mosfets system, thus more resistant against tension peaks, even if impulsive.
- an in-built current reading system which controls the current sinusoid and the relay commutation time.

What's the advantage? Rectifier is normally the "brain" and the fragile point of any dc brake motor. This rectifier is stronger against disturbs coming from power line, much stronger than what required by European EMC rules for industrial environment; they are more resistant against vibrations, and they are faster.



The technical files with all performance data and PDF drawings of each motor, can be downloaded from www.motive.it "configurator" section

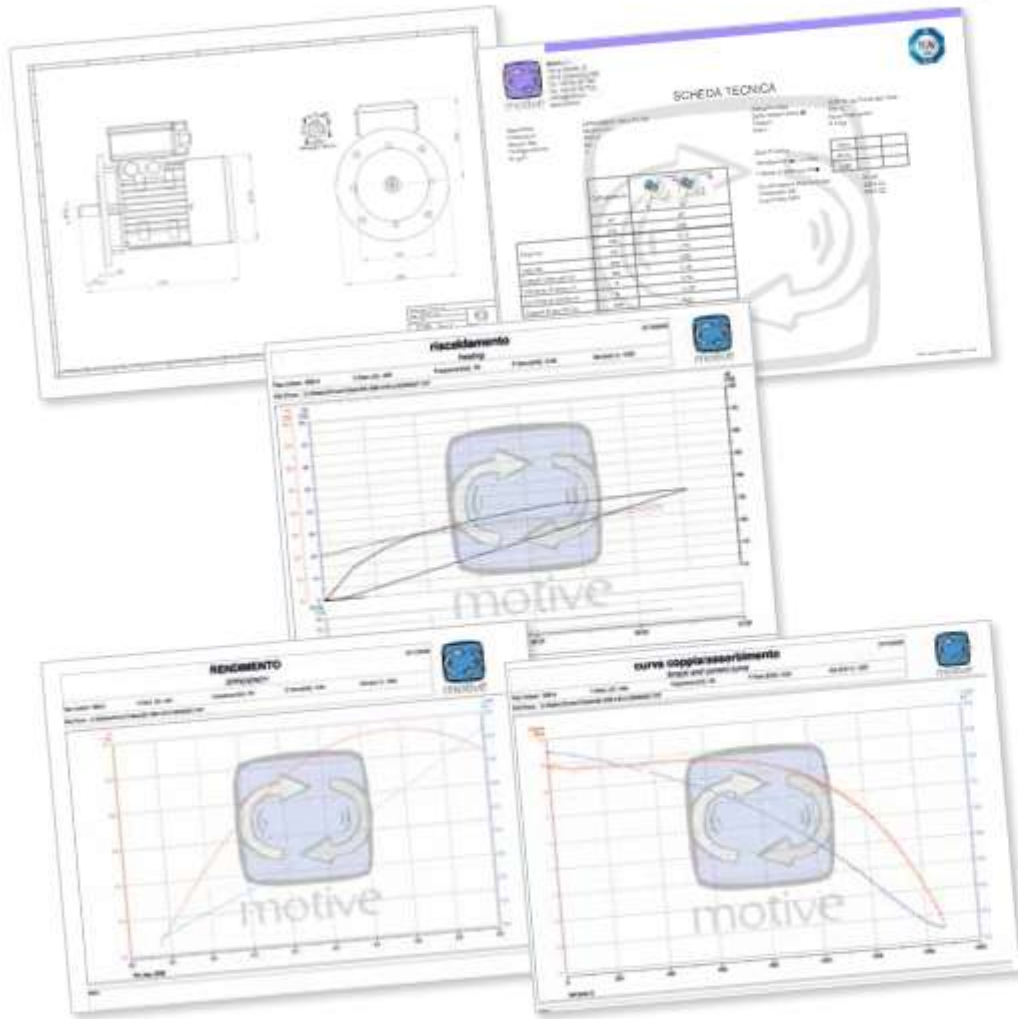

NOTE: motors can be improved in any moment. The data in www.motive.it can be more updated.

Each data is even more detailed and proven by the type test reports loaded in www.motive.it



You can download each motor or gearbox final test report from www.motive.it, starting from its serial number

ASK OUR FURTHER CATALOGUES:



Motive s.r.l.

Via Le Ghiselle, 20

25014 Castenedolo (BS) - Italy

Tel.: +39.030.2677087 - Fax: +39.030.2677125

web site: www.motive.it

e-mail: motive@motive.it



AREA DISTRIBUTOR